

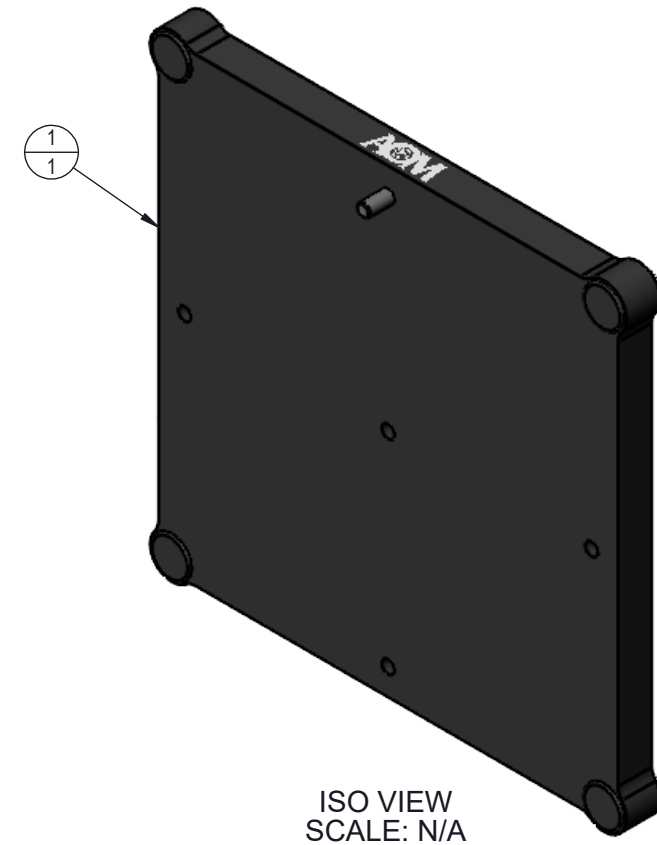

NOTES, UNLESS OTHERWISE SPECIFIED:  
 1. FOR REFERENCE ONLY.

REV.	DESCRIPTION	DATE	APPROVED
A	INITIAL RELEASE	8/16/2023	C. MERLE

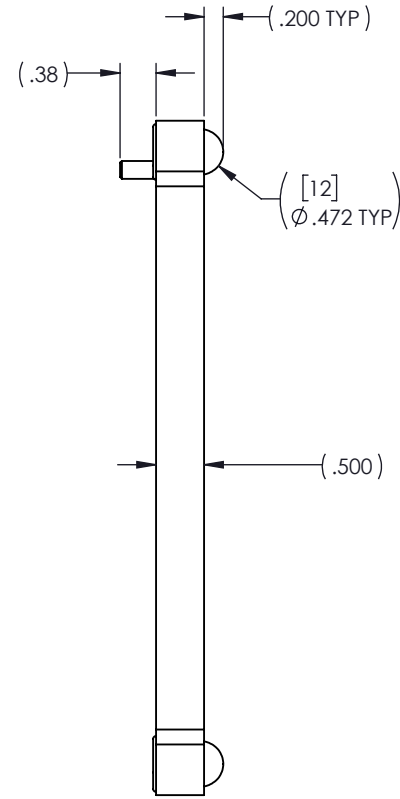
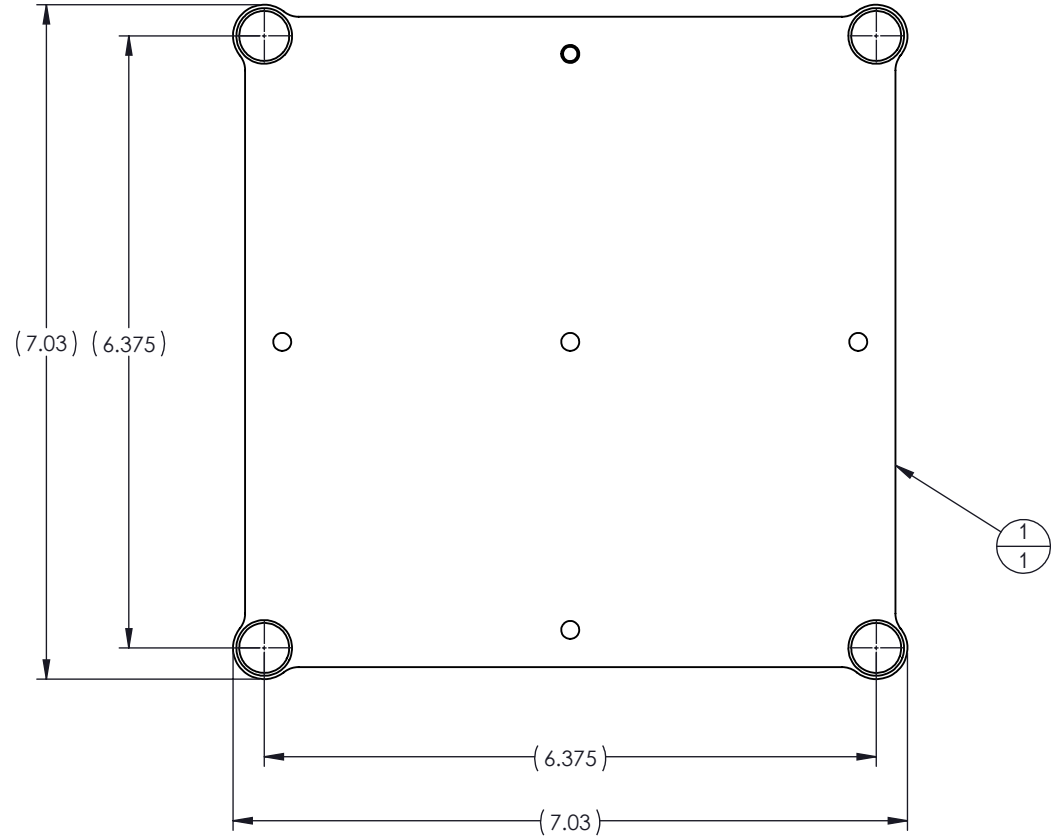

ITEM NO.	QTY.	PART NUMBER	DESCRIPTION
1	1	20-00007-00	ASSY, MP, 6 3/8 X 12MM

THIS DOCUMENT CONTAINS INFORMATION WHICH IS PROPRIETARY TO ARIZONA OPTICAL METROLOGY. NO REPRODUCTION OR PUBLICATION OF THIS DOCUMENT, IN WHOLE OR IN PART, SHALL BE MADE WITHOUT WRITTEN AUTHORIZATION FROM ARIZONA OPTICAL METROLOGY.	TOLERANCES			 ARIZONA OPTICAL METROLOGY 2420 W Ruthrauff Rd #160 TUCSON, AZ 85705 Phone: 520-833-5761 Email: info@CGHnulls.com	
	PLACES IN DIMENSION	.X	.XX		.XXX
	DIMENSIONS	±.05	±.01		±.005
	ANGLES	±.5°			
	FRACTIONS	±1/32			
UNLESS OTHERWISE SPECIFIED: ALL DIMENSIONS ARE IN INCHES AND APPLY AFTER COATING/PLATING.	MATERIAL: N/A			TITLE	
DRAWING STANDARD PER: ASME Y14.5-2009 INTERPRET WELDING SYMBOLS PER AWS A2.4	HEAT TREAT: N/A			PLATFORM, METROLOGY, BLANK, MP6	
REMOVE ALL BURRS AND EDGE BREAK .01" MAXIMUM	FINISH: N/A			SIZE	
	DESIGN BY:	DATE:		<b>B</b>	
	A. CLARK	3/27/2023		DWG NO.	
	DRAWN BY:	DATE:		<b>MP6-BLANK</b>	
	A. CLARK	3/27/2023		REV.	
	CHECKED BY:	DATE:		<b>A</b>	
	T. GROSS	8/16/2023		SCALE	
DO NOT SCALE DRAWING				1:2	
				WEIGHT	
				2.30 LBS	
				SHEET	
				1 OF 1	