

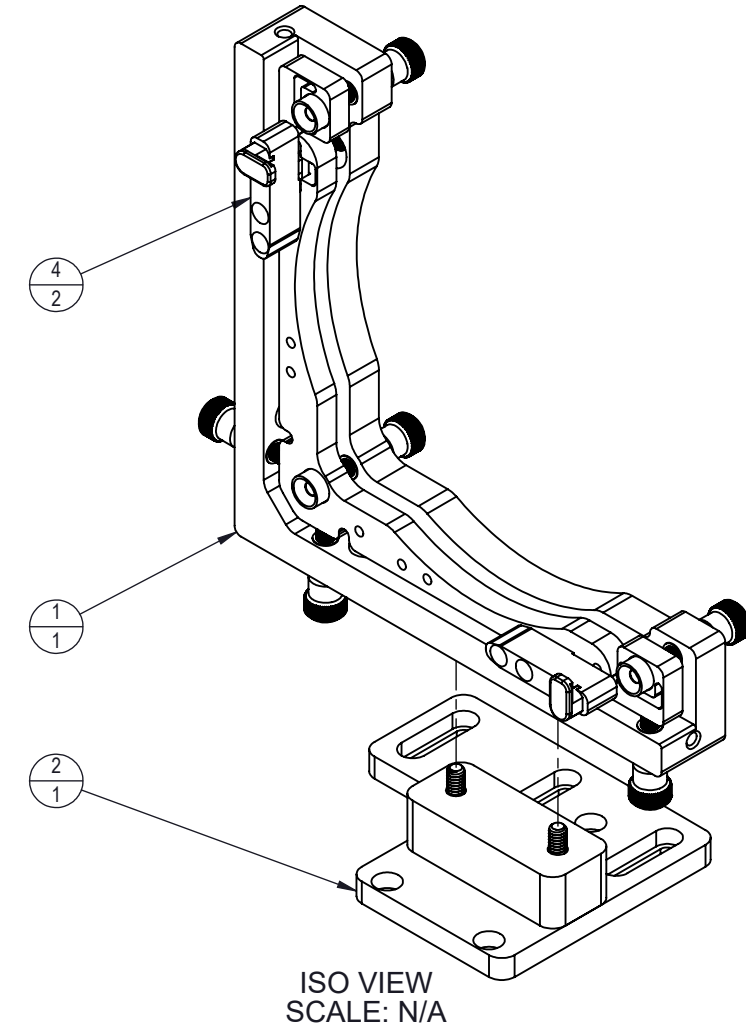

NOTES, UNLESS OTHERWISE SPECIFIED:
 1. FOR REFERENCE ONLY.

| REV. | DESCRIPTION | DATE | APPROVED |
|------|--|-----------|-------------|
| A | INITIAL RELEASE | 4/20/2022 | J. BEVERAGE |
| B | ADDED ITEMS 3 & 4 AND UPDATED GEOMETRY | 1/6/2023 | J. BEVERAGE |

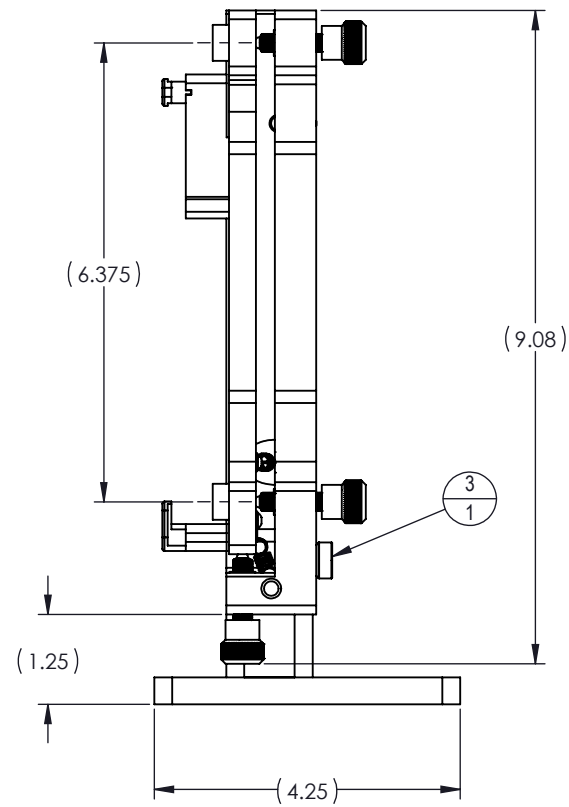
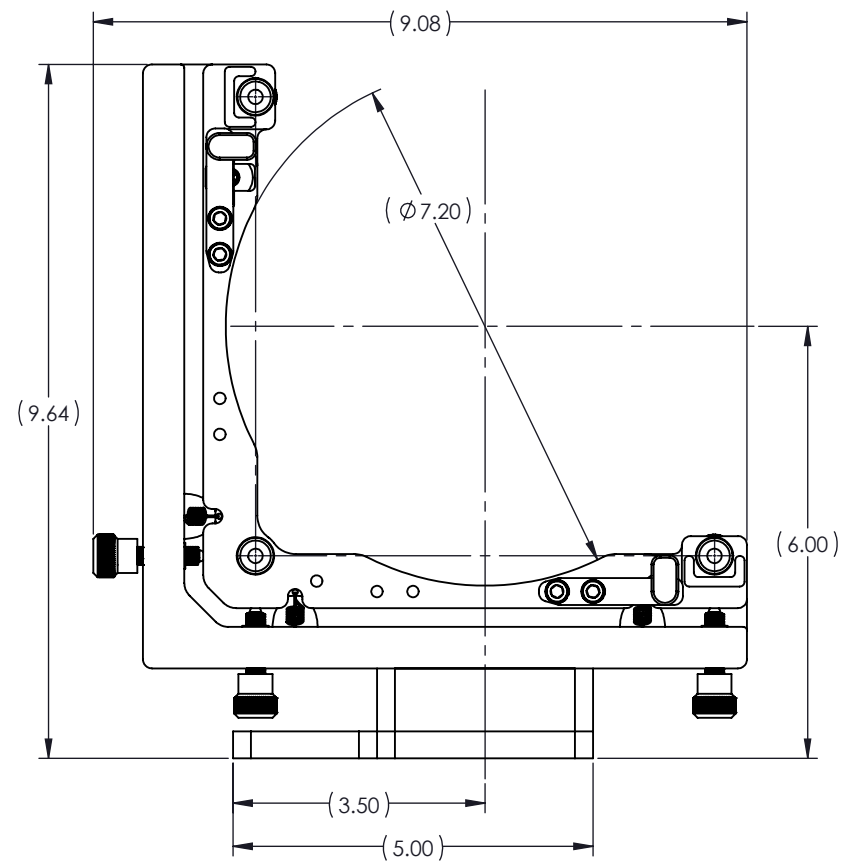
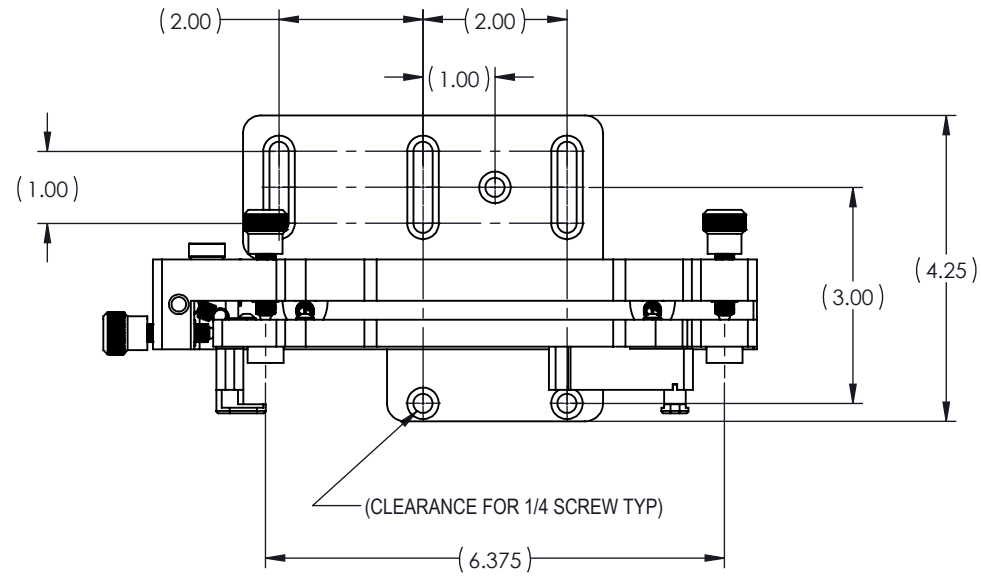

| ITEM NO. | QTY. | PART NUMBER | DESCRIPTION |
|----------|------|-------------|---------------------------|
| 1 | 1 | 20-00001 | ASSY, STAGE, 6 3/8 X 12MM |
| 2 | 1 | 20-00003 | KIT, BASE, FP6, 6 CL |
| 3 | 1 | 20-00017 | ASSY, SPACER, SEAT, 2° |
| 4 | 2 | 20-00077 | ASSY, CLAMP, CANTILEVERED |

| | | | | |
|---|--|--|---|--|
| THIS DOCUMENT CONTAINS INFORMATION WHICH IS PROPRIETARY TO ARIZONA OPTICAL METROLOGY. NO REPRODUCTION OR PUBLICATION OF THIS DOCUMENT, IN WHOLE OR IN PART, SHALL BE MADE WITHOUT WRITTEN AUTHORIZATION FROM ARIZONA OPTICAL METROLOGY. | TOLERANCES PLACES IN DIMENSION: .X .XX .XXX DIMENSIONS: ±.05 ±.01 ±.005 ANGLES: ±.5° FRACTIONS: ±1/32 | | |  ARIZONA OPTICAL METROLOGY 2420 W RUTHRAUFF RD #160 TUCSON, AZ 85705 Phone: 520-833-5761 Email: info@CGHnulls.com |
| | MATERIAL: N/A HEAT TREAT: N/A FINISH: N/A | | | |
| UNLESS OTHERWISE SPECIFIED: ALL DIMENSIONS ARE IN INCHES AND APPLY AFTER COATING/PLATING. | DESIGN BY: C CALDWELL DATE: 4/20/2022 | DRAWN BY: C CALDWELL DATE: 4/20/2022 | TITLE: 6-DOF C6 FINE POSITIONING STAGE, 6" CL | SIZE: B DWG NO.: FP6-H600 REV.: B |
| DRAWING STANDARD PER: ASME Y14.5-2009 INTERPRET WELDING SYMBOLS PER AWS A2.4 | REMOVE ALL BURRS AND EDGE BREAK .01" MAXIMUM | CHECKED BY: J. BEVERAGE DATE: 4/20/2022 | SCALE: 3:8 WEIGHT: 3.19 LBS SHEET: 1 OF 1 | |