

NOTES, UNLESS OTHERWISE SPECIFIED:  
 1. FOR REFERENCE ONLY.

REV.	DESCRIPTION	DATE	APPROVED
A	INITIAL RELEASE	1/9/2023	A. CLARK
B	UPDATED FROM 1 TO 1/2 TRAVEL	3/17/2023	J. BEVERAGE

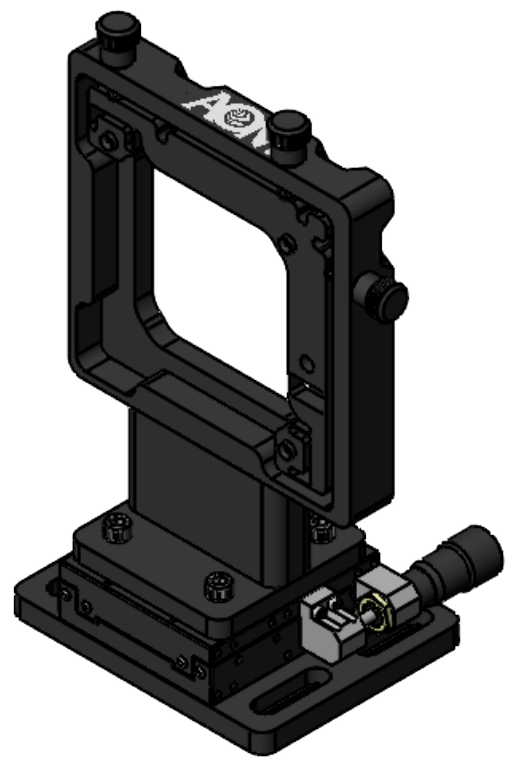

-01 (CENTER MOUNTED)  
NOT TO SCALE

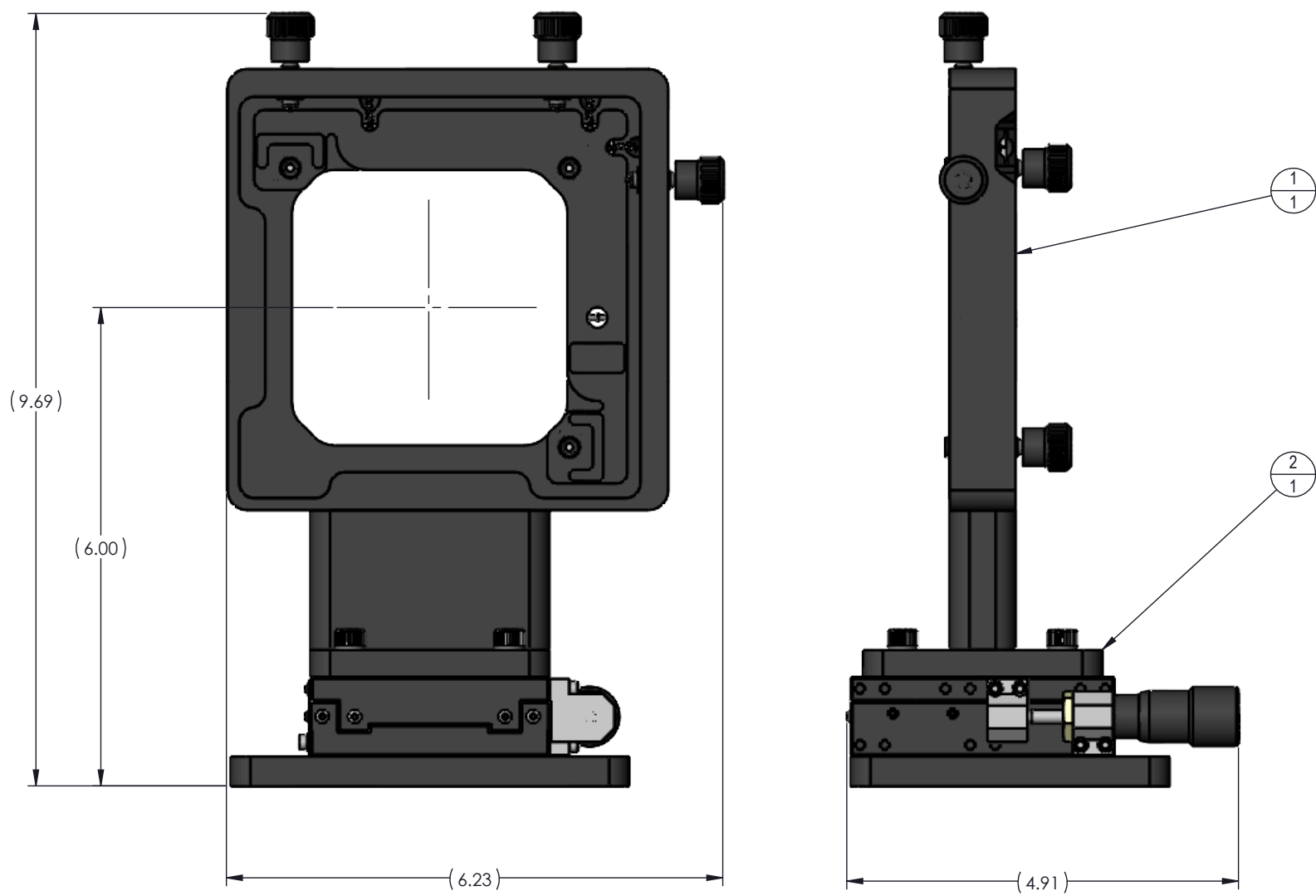
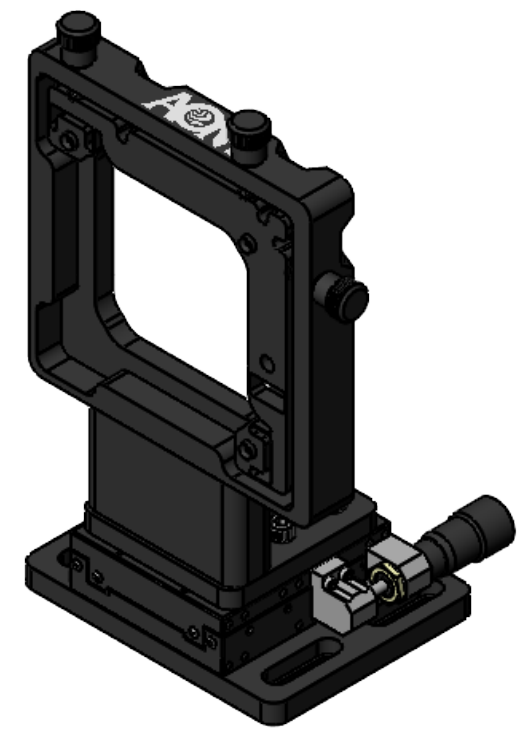

-02 (END MOUNTED)  
NOT TO SCALE

ITEM NO.	QTY.	PART NUMBER	DESCRIPTION
1	1	20-00004	ASSY, STAGE, 3 1/2 X 1/4
2	1	20-00096	KIT, BASE, FP3-Z, 6 CL

THIS DOCUMENT CONTAINS INFORMATION WHICH IS PROPRIETARY TO ARIZONA OPTICAL METROLOGY. NO REPRODUCTION OR PUBLICATION OF THIS DOCUMENT, IN WHOLE OR IN PART, SHALL BE MADE WITHOUT WRITTEN AUTHORIZATION FROM ARIZONA OPTICAL METROLOGY.	TOLERANCES			 ARIZONA OPTICAL METROLOGY 2420 W Ruthrauff Rd #160 TUCSON, AZ 85705 Phone: 520-833-5761 Email: info@CGHnulls.com	
	PLACES IN DIMENSION	.X	.XX		.XXX
	DIMENSIONS	±.05	±.01		±.005
	ANGLES	±.5°			
	FRACTIONS	±1/32			
	MATERIAL: N/A				
	HEAT TREAT: N/A				
	FINISH: N/A				
DRAWING STANDARD PER: ASME Y14.5-2009 INTERPRET WELDING SYMBOLS PER AWS A2.4	DESIGN BY: A. CLARK	DATE: 7/26/2022			
REMOVE ALL BURRS AND EDGE BREAK .01" MAXIMUM	DRAWN BY: A. CLARK	DATE: 7/26/2022			
	CHECKED BY: J. BEVERAGE	DATE: 1/6/2023			
DO NOT SCALE DRAWING	TITLE 6-DOF C3 FINE POSITIONING STAGE, 6" CL		SIZE B	DWG NO. FP3-Z-H600	
	SCALE 1:2	WEIGHT 3.67 LBS	REV. B		
	SHEET 1 OF 1				