

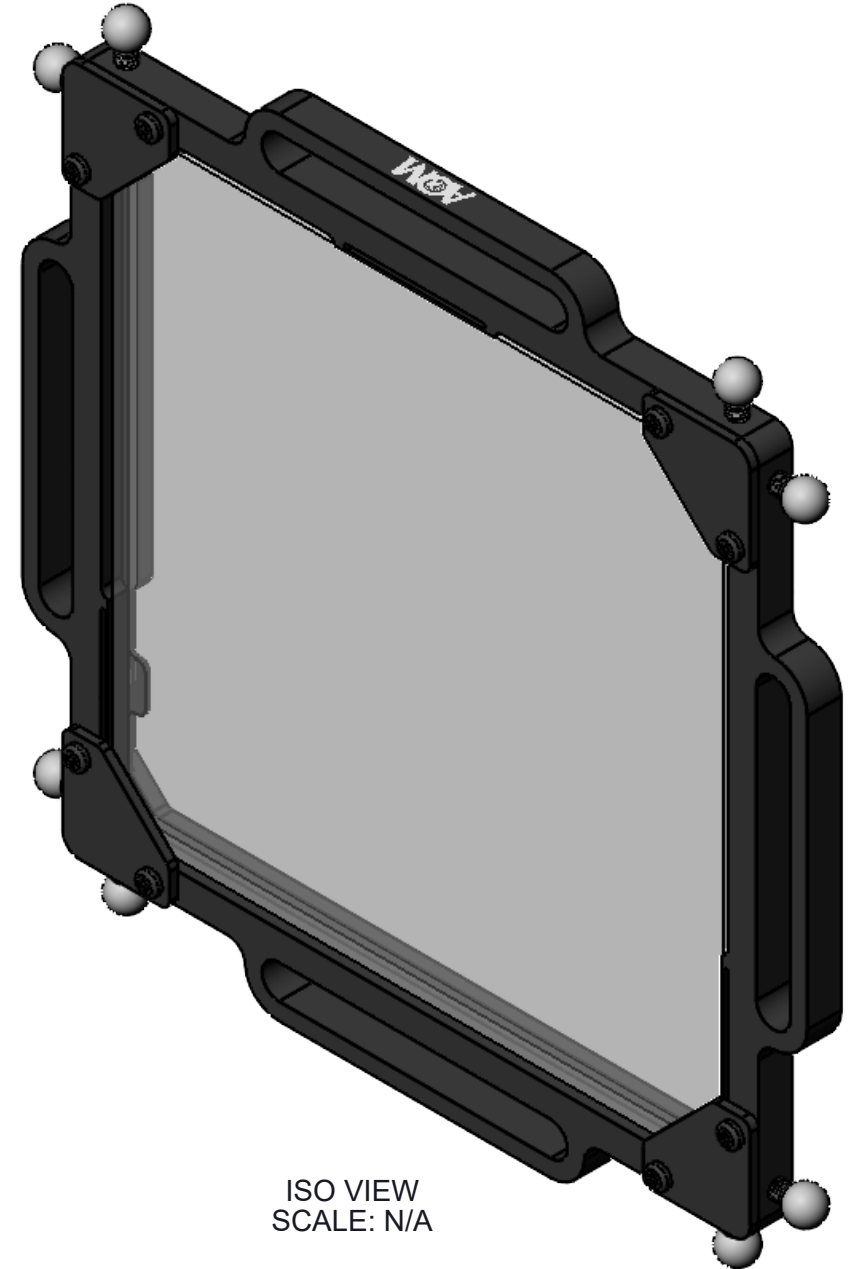

| REV. | DESCRIPTION     | DATE      | APPROVED |
|------|-----------------|-----------|----------|
| A    | INITIAL RELEASE | 10/3/2023 | C. MERLE |

| ITEM NO. | QTY. | PART NUMBER | DESCRIPTION     |
|----------|------|-------------|-----------------|
| 1        | 1    | 60-00009-XX | CGH ASSY, S9-C9 |

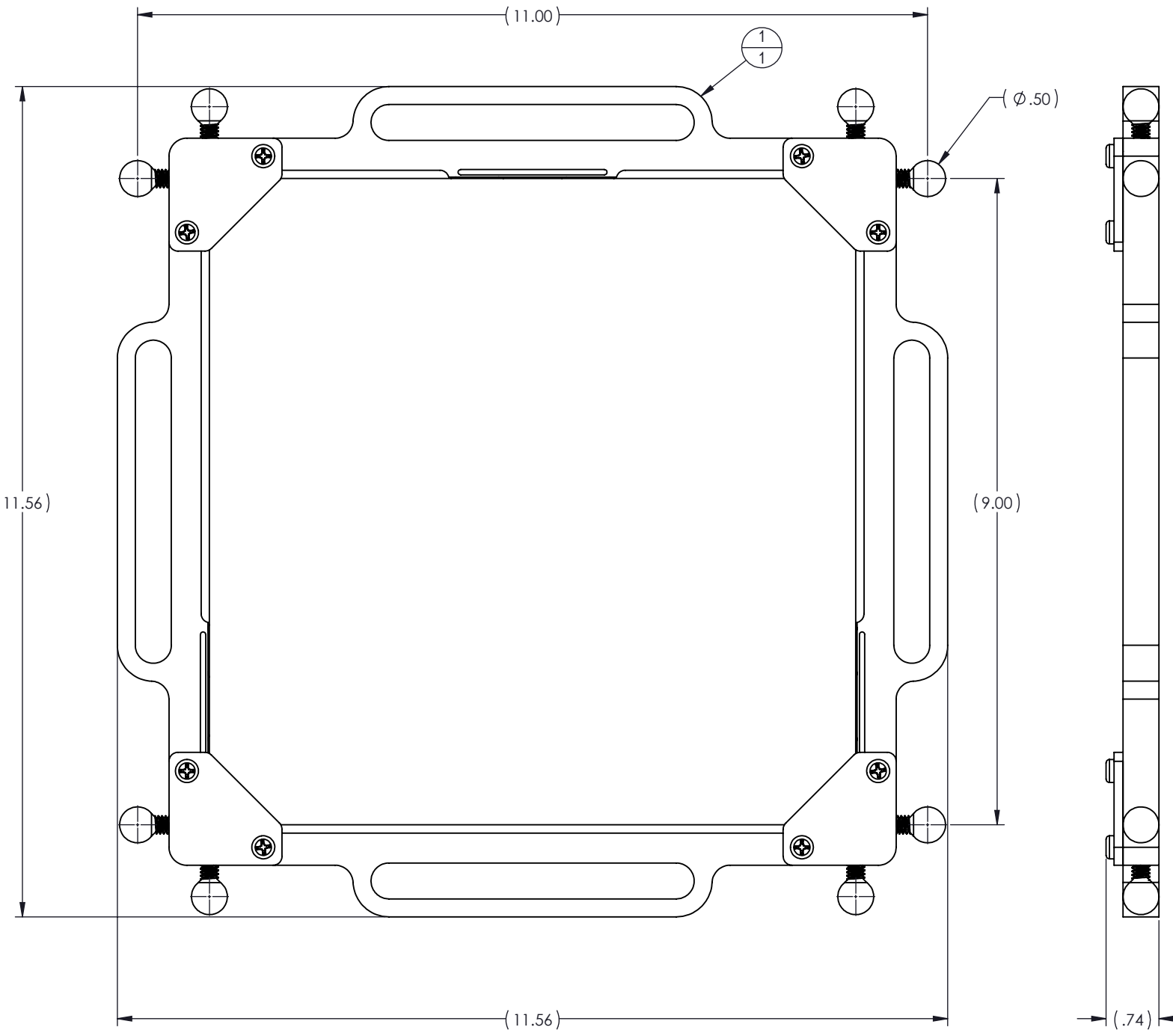

|   |                      |                 |             |   |  |
|---|----------------------|-----------------|-------------|---|--|
| THIS DOCUMENT CONTAINS INFORMATION WHICH IS PROPRIETARY TO ARIZONA OPTICAL METROLOGY. NO REPRODUCTION OR PUBLICATION OF THIS DOCUMENT, IN WHOLE OR IN PART, SHALL BE MADE WITHOUT WRITTEN AUTHORIZATION FROM ARIZONA OPTICAL METROLOGY. | TOLERANCES           |                 |             |  | ARIZONA OPTICAL METROLOGY<br>2420 W Ruthrauff Rd #160<br>TUCSON, AZ 85705<br>Phone: 520-833-5761<br>Email: info@CGHnulls.com |
|   | PLACES IN DIMENSION  | .X              | .XX         |   |  |
| UNLESS OTHERWISE SPECIFIED: ALL DIMENSIONS ARE IN INCHES AND APPLY AFTER COATING/PLATING.   | DIMENSIONS           | ±.05            | ±.01        | ±.005   | TITLE<br><b>CGH, 9-IN SUBSTRATE, C9 CELL</b>   |
| DRAWING STANDARD PER: ASME Y14.5-2009 INTERPRET WELDING SYMBOLS PER AWS A2.4  | ANGLES               | ±.5°            |             |   |  |
| REMOVE ALL BURRS AND EDGE BREAK .01" MAXIMUM  | FRACTIONS            | ±1/32           |             |   | SIZE <b>B</b> DWG NO. <b>CGH-S9-C9</b> REV. <b>A</b>   |
| DO NOT SCALE DRAWING  | MATERIAL: N/A        | HEAT TREAT: N/A | FINISH: N/A | SCALE 1:2   | WEIGHT 3.08 LBS SHEET 1 OF 1   |
|   | DESIGN BY: A. CLARK  | DATE: 2/27/2023 |             |   |  |
|   | DRAWN BY: A. CLARK   | DATE: 2/27/2023 |             |   |  |
|   | CHECKED BY: T. GROSS | DATE: 7/28/2023 |             |   |  |