

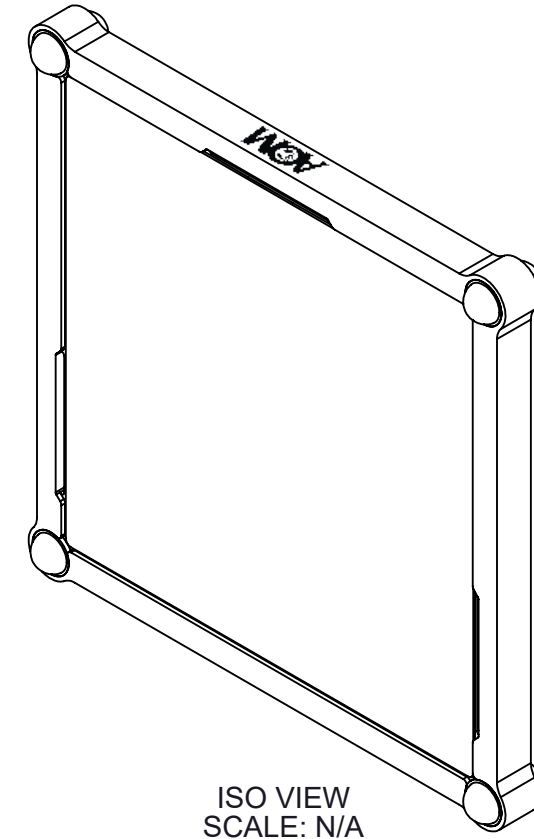

NOTES, UNLESS OTHERWISE SPECIFIED:
 1. ITEMS 2 AND 3 ARE NOT SHOWN.

REV.	DESCRIPTION	DATE	APPROVED
A	INITIAL RELEASE	2/24/2023	A. CLARK

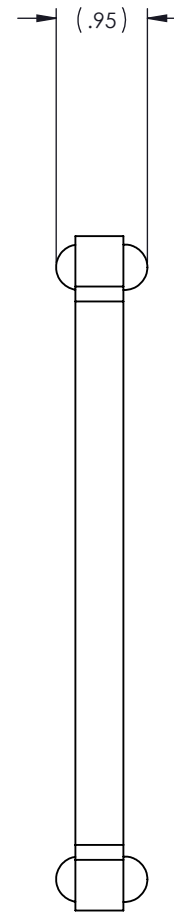
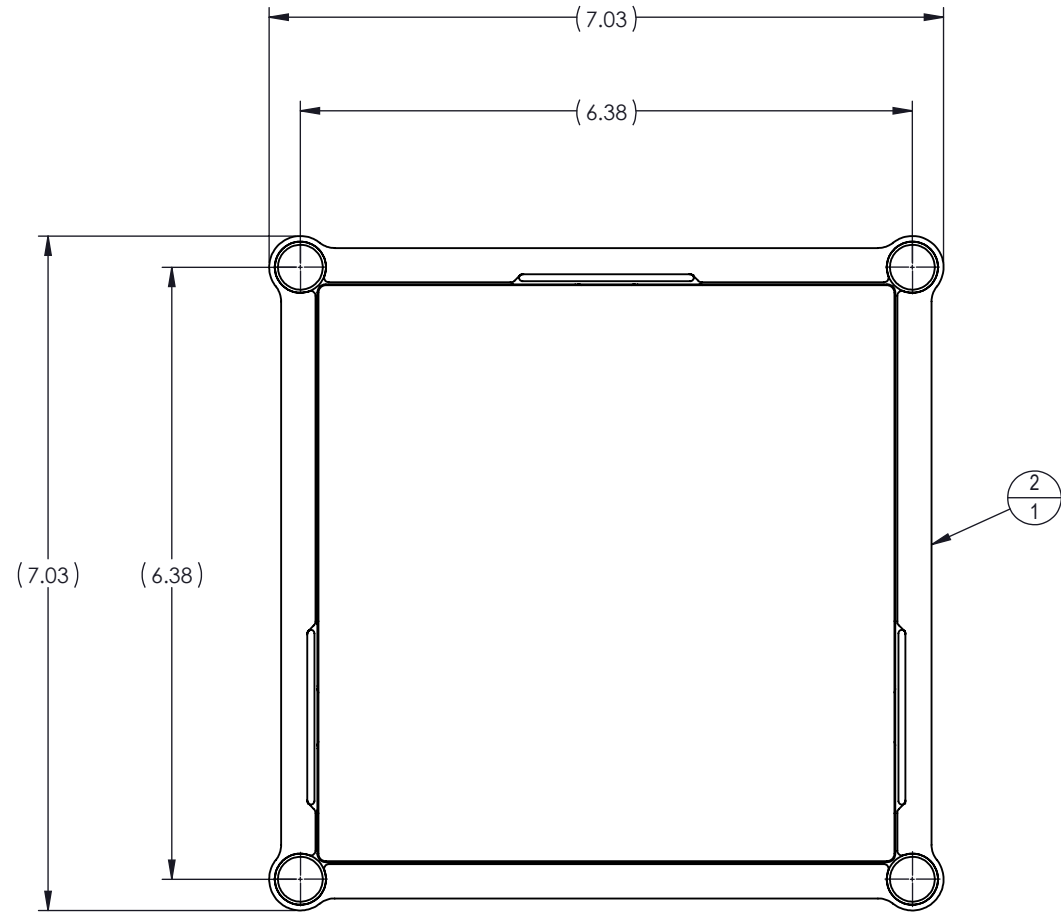

CGH-S6-C6

ITEM NO.	QTY.	PART NUMBER	DESCRIPTION
1	1	60-00001-XX	ASSY, CGH, S6-C6
2	1	20-00062	SET, FOAM, C6, 9X9 COMPACT
3	1	30-00001	BOX, C6 CGH ASSY, ABS

THIS DOCUMENT CONTAINS INFORMATION WHICH IS PROPRIETARY TO ARIZONA OPTICAL METROLOGY. NO REPRODUCTION OR PUBLICATION OF THIS DOCUMENT, IN WHOLE OR IN PART, SHALL BE MADE WITHOUT WRITTEN AUTHORIZATION FROM ARIZONA OPTICAL METROLOGY.	TOLERANCES			 ARIZONA OPTICAL METROLOGY 2420 W Ruthrauff Rd #160 TUCSON, AZ 85705 Phone: 520-833-5761 Email: info@CGHnulls.com	
	PLACES IN DIMENSION	.X	.XX		.XXX
	DIMENSIONS	±.05	±.01		±.005
	ANGLES	±.5°			
REMOVE ALL BURRS AND EDGE BREAK .01" MAXIMUM	FRACTIONS	±1/32		TITLE CGH, 6-IN SUBSTRATE, C6 CELL	
UNLESS OTHERWISE SPECIFIED: ALL DIMENSIONS ARE IN INCHES AND APPLY AFTER COATING/PLATING.	MATERIAL: N/A				
DRAWING STANDARD PER: ASME Y14.5-2009 INTERPRET WELDING SYMBOLS PER AWS A2.4	HEAT TREAT: N/A	FINISH: N/A		SIZE B DWG NO. CGH-S6-C6-XX REV. A	
DO NOT SCALE DRAWING	DESIGN BY: A. CLARK	DATE: 9/8/2022	SCALE 1:2	WEIGHT 1.85 LBS SHEET 1 OF 3	
	DRAWN BY: A. CLARK	DATE: 9/8/2022			
	CHECKED BY: J. BEVERAGE	DATE: 2/21/2023			

NOTES, UNLESS OTHERWISE SPECIFIED:
 1. ITEMS 2 AND 3 ARE NOT SHOWN.

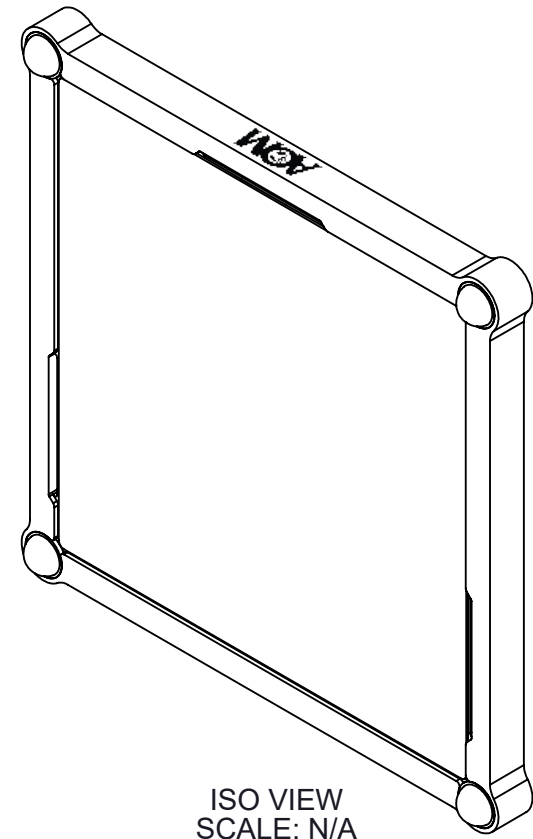
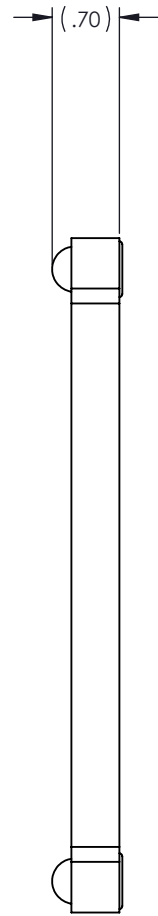
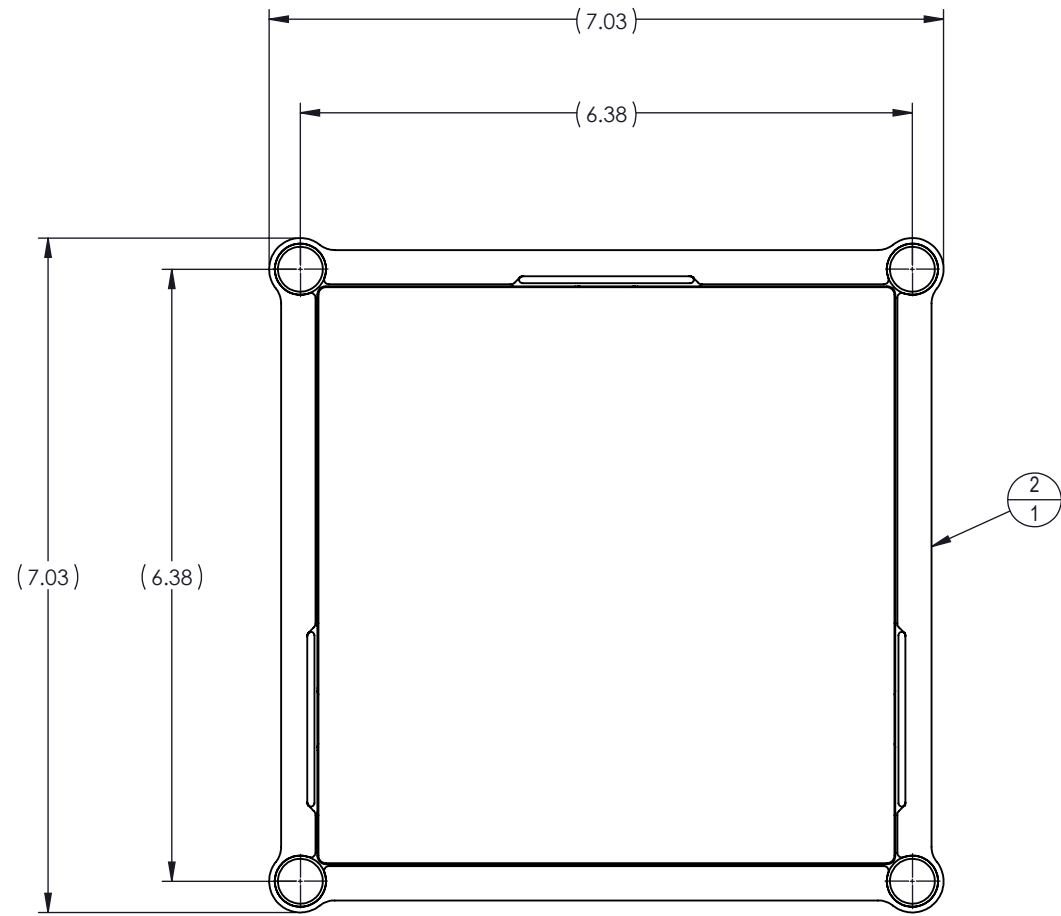

CGH-S6-C6-BP

ITEM NO.	QTY.	PART NUMBER	DESCRIPTION
1	1	60-00001-XX	ASSY, CGH, S6-C6
2	1	20-00062	SET, FOAM, C6, 9X9 COMPACT
3	1	30-00001	BOX, C6 CGH ASSY, ABS

THIS DOCUMENT CONTAINS INFORMATION WHICH IS PROPRIETARY TO ARIZONA OPTICAL METROLOGY. NO REPRODUCTION OR PUBLICATION OF THIS DOCUMENT, IN WHOLE OR IN PART, SHALL BE MADE WITHOUT WRITTEN AUTHORIZATION FROM ARIZONA OPTICAL METROLOGY.	TOLERANCES			 ARIZONA OPTICAL METROLOGY 2420 W RUTHRAUFF RD #160 TUCSON, AZ 85705 Phone: 520-833-5761 Email: info@CGHnulls.com	
	PLACES IN DIMENSION	.X	.XX		.XXX
	DIMENSIONS	±.05	±.01		±.005
	ANGLES	±.5°			
	FRACTIONS	±1/32			
UNLESS OTHERWISE SPECIFIED: ALL DIMENSIONS ARE IN INCHES AND APPLY AFTER COATING/PLATING.	MATERIAL: N/A			TITLE CGH, 6-IN SUBSTRATE, C6 CELL	
DRAWING STANDARD PER: ASME Y14.5-2009 INTERPRET WELDING SYMBOLS PER AWS A2.4	HEAT TREAT: N/A				
REMOVE ALL BURRS AND EDGE BREAK .01" MAXIMUM	FINISH: N/A			SIZE B	
	DESIGN BY: A. CLARK	DATE: 9/8/2022	DWG NO. CGH-S6-C6-XX		
	DRAWN BY: A. CLARK	DATE: 9/8/2022	REV. A		
	CHECKED BY: J. BEVERAGE	DATE: 2/21/2023	SCALE 1:2	WEIGHT 1.80 LBS	
DO NOT SCALE DRAWING			SHEET 2 OF 3		

NOTES, UNLESS OTHERWISE SPECIFIED:
 1. ITEMS 2 AND 3 ARE NOT SHOWN.

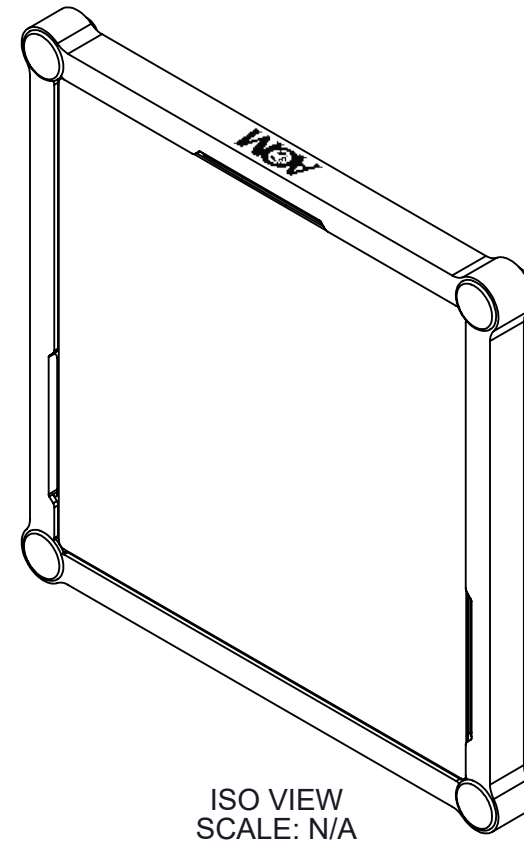
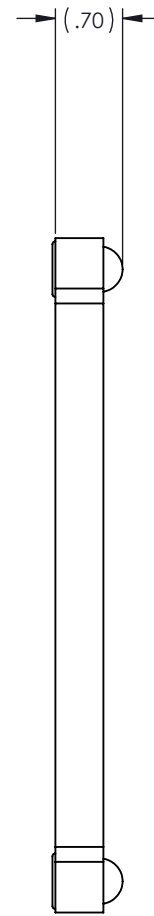
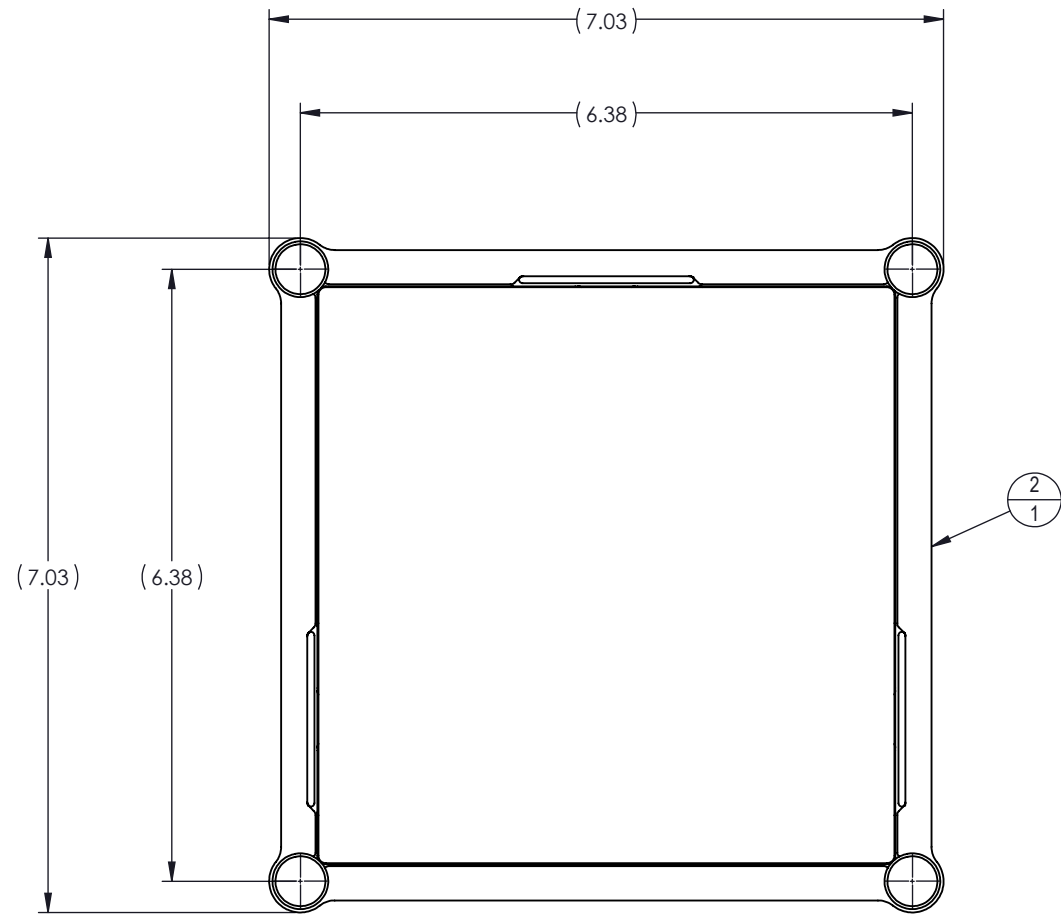

CGH-S6-C6-BC

ITEM NO.	QTY.	PART NUMBER	DESCRIPTION
1	1	60-00001-XX	ASSY, CGH, S6-C6
2	1	20-00062	SET, FOAM, C6, 9X9 COMPACT
3	1	30-00001	BOX, C6 CGH ASSY, ABS

THIS DOCUMENT CONTAINS INFORMATION WHICH IS PROPRIETARY TO ARIZONA OPTICAL METROLOGY. NO REPRODUCTION OR PUBLICATION OF THIS DOCUMENT, IN WHOLE OR IN PART, SHALL BE MADE WITHOUT WRITTEN AUTHORIZATION FROM ARIZONA OPTICAL METROLOGY.	TOLERANCES			 ARIZONA OPTICAL METROLOGY 2420 W Ruthrauff Rd #160 TUCSON, AZ 85705 Phone: 520-833-5761 Email: info@CGHnulls.com	
	PLACES IN DIMENSION	.X	.XX		.XXX
	DIMENSIONS	±.05	±.01		±.005
	ANGLES	±.5°			
REMOVE ALL BURRS AND EDGE BREAK .01" MAXIMUM	FRACTIONS	±1/32		TITLE CGH, 6-IN SUBSTRATE, C6 CELL	
UNLESS OTHERWISE SPECIFIED: ALL DIMENSIONS ARE IN INCHES AND APPLY AFTER COATING/PLATING.	MATERIAL: N/A				
DRAWING STANDARD PER: ASME Y14.5-2009 INTERPRET WELDING SYMBOLS PER AWS A2.4	HEAT TREAT: N/A	FINISH: N/A	DATE: 9/8/2022	SIZE B DWG NO. CGH-S6-C6-XX REV. A	
DO NOT SCALE DRAWING	DESIGN BY: A. CLARK	DATE: 9/8/2022	CHECKED BY: J. BEVERAGE	SCALE 1:2 WEIGHT 1.80 LBS SHEET 3 OF 3	